



NATIONAL COMFORT PRODUCTS
HEATING & A/C EQUIPMENT

Thru-the-Wall Comfort for all types of Multi-Family Construction

Installation Guide

Split-System Condensing Units

This unit should be installed in an

OUTSIDE WALL FOR THRU-THE-WALL INSTALLATION ONLY!

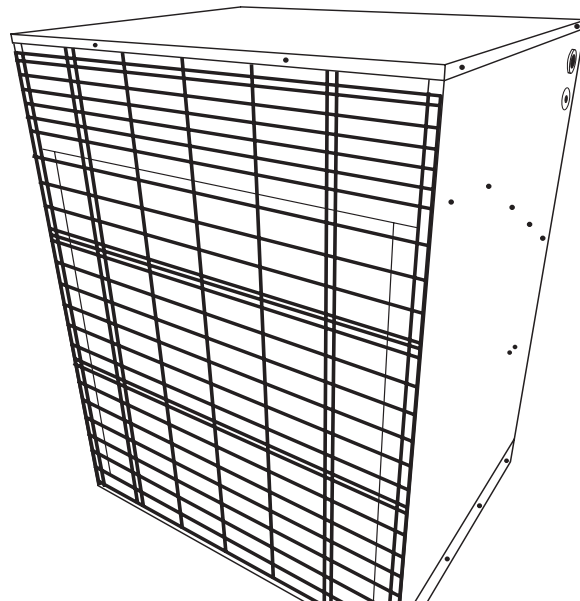

All Units Department of Energy Listed

*Please consult the DOE Compliance Certification Database (<https://tinyurl.com/NCPCCondensers>) for a list of rated combinations of indoor and outdoor units.

NCP

Series:

1000

3000

4000

5000



Please fill in the following information and file it for future reference.

MODEL NO. _____

SERIAL NO. _____

INSTALL DATE _____

Go Thru-the-Wall

NATIONAL COMFORT PRODUCTS
HEATING & A/C EQUIPMENT

National Comfort Products
A Division of National Refrigeration and Air Conditioning Products, Inc.
539 Dunksferry Road • Bensalem, PA 19020-5908
(800) 523-7138 • Fax (215) 639-1674
www.nationalcomfortproducts.com

	Page
Safety Warning	3
Before You Start.....	3
Check for Clearances	4
Unit Location Considerations	4
Refrigerant Piping Limits	4
Leak Checking.....	6
Evacuation, Electrical Connections.....	7
High Voltage and Power Supply.....	8
Start Up, Sequence of Operations	9
Refrigerant Charging.....	10
Maintenance, Checkout Procedure.....	11
Noise, Insulated Sound Cover	12
Important! Before Removing a Warranty Compressor.....	13
Wiring Diagrams	14
Specifications, Dimensional Drawings.....	15-16
Matched systems with Cased Coils	17
Matched systems with Air Handlers.....	17
Replacement Parts - NCP 1000 Series.....	18
Replacement Parts - NCP 3000 Series.....	18
Replacement Parts - NCP 4000 Series.....	19
Replacement Parts - NCP 5000 Series.....	20
Warranty	21-22

**IMPORTANT NOTE: DO NOT DESTROY OR THROW AWAY THIS MANUAL.
IT SHOULD BE KEPT IN A SAFE PLACE FOR FUTURE REFERENCE.**

Safety Warnings!

⚠ WARNING

 **HIGH VOLTAGE!** Disconnect ALL power before servicing. Multiple power sources may be present. Failure to do so may result in property damage, personal injury or death.

⚠ WARNING

These instructions are intended as an aid to qualified, licensed service personnel for proper installation, adjustment and operation of this unit. **Read these instructions thoroughly before attempting installation or operation.** Failure to follow these instructions may result in improper installation, adjustment, service or maintenance possibly resulting in fire, electrical shock, property damage, personal injury or death.

⚠ WARNING

Installation and repair of this unit should be performed **ONLY** by individuals meeting the requirements of an “entry level technician” as specified by National Codes. Attempting to install or repair this unit without such background may result in product damage, personal injury or death.

⚠ CAUTION

Use care when handling scroll compressors. Some temperatures could be hot!

⚠ CAUTION

Scroll compressors should **NEVER** be used to evacuate the air conditioning system. Vacuums this low can cause internal electrical arcing resulting in a damaged or failed compressor.

⚠ WARNING

The unit must be permanently grounded. **Failure to do so can cause electrical shock resulting in severe personal injury or death.**

“USE COPPER SUPPLY WIRES ONLY”

⚠ WARNING

Do not use oxygen to purge lines or pressurize system for leak test. Oxygen reacts violently with oil, which can cause an explosion resulting in severe personal injury or death.

⚠ WARNING

Extreme caution should be exercised when opening the Liquid Line Service Valve. Turn counter clockwise until the valve stem just touches the rolled edge. No torque is required. Failure to follow this warning will result in abrupt release of system charge and may result in personal injury and /or property damage.

Before You Start

ALL phases of this installation must comply with NATIONAL, STATE AND LOCAL CODES. The manufacturer assumes no responsibility for equipment installed in violation of any code requirements.

Be sure that the electrical data specified on the unit rating plate corresponds to what is available at the installation site and NEC for installation requirements.

This unit MUST be installed in an outside wall for thru-the-wall installation ONLY. No pad mounts.

Be sure that the electrical service provided to the building can handle the load imposed by the unit.

IMPORTANT — This Document is customer property and is to remain with this unit. Please refer to service information pack upon completion of work to register the unit’s warranty. These instructions do not cover all variations in systems or provide for every possible contingency to be met in connection with the installation. Should further information be desired or should particular problems arise which are not covered sufficiently for the purchaser’s purposes, the matter should be referred to your installing dealer or local distributor before contacting the manufacturer.

Note: The manufacturer recommends installing only approved matched split systems. Our split systems are A.H.R.I. and DOE rated only with TXV indoor systems. (Please consult the DOE Compliance Certification Database (<https://tinyurl.com/NCPCCondensers>) for a list of rated combinations of indoor and outdoor units. Combinations of outdoor and indoor units that are not rated will require factory testing and listing with DOE. Please consult the factory.) Some of the benefits of installing approved matched split systems are maximum efficiency, optimum performance and the best overall system reliability. Self-equalizing components are required to reduce compressor starting problems. If self-equalizing components are not used, field installed hard start kits will be required. Hard start kits **MUST** be compatible with compressors.

Hard start kits **MUST** be compatible with Copeland compressors - 88-106/330 µF/Volts

Start relays to be sized to µF of capacitor used.

The unit must **never** be placed on its side or upside down as the compressor oil will run in the cooling circuit and seriously damage the unit. Base pan must always be on the bottom of the install.

Check for Clearances

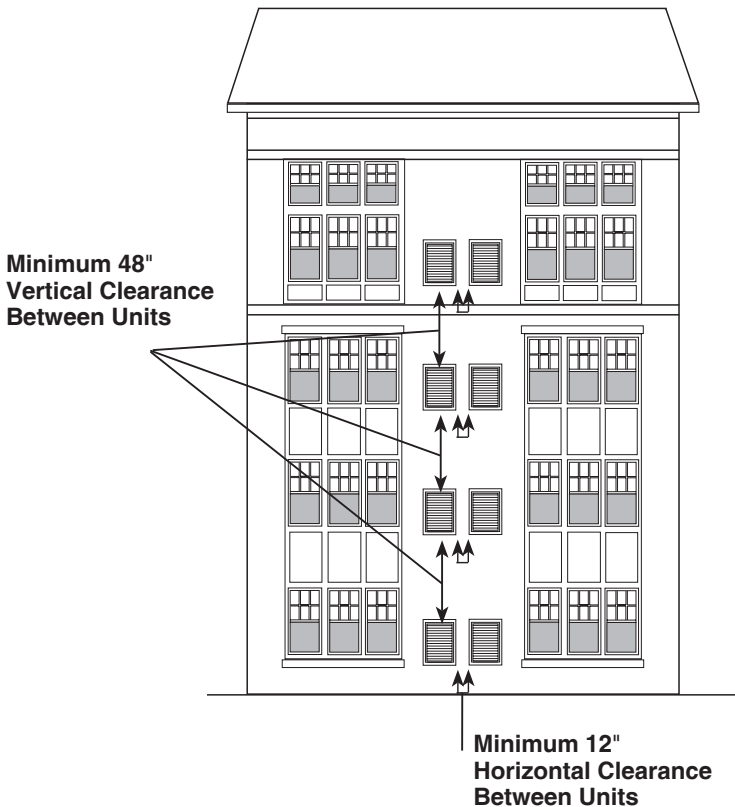

WARNING: Warranty will be void on all units installed behind brick facades (e.g. pigeon holes) or connected to ductwork (See Note 1 below). All obstacles added to impede air flow of the condensing unit will decrease performance, cause premature equipment failure, and void all warranties. Consult factory with any questions.

Note 1: No ducts are permitted to be connected to the intake or discharge of the unit.

Unit Location Considerations

In thru-the-wall installation, due to the various types of wall construction, it is not possible to provide detailed instructions. The following is a list of general requirements and cautions for installing these units. **The unit must be installed level, both - top front to back and left to right.**

1. Masonry walls must have a lintel to support the wall.
2. Extend the unit approximately 3/4" beyond outside surface of the wall. Optional mounting angles can be purchased from the factory or field fabricated for locating and mounting the unit in the wall.

3. The wall opening across the top and bottom must be flashed. Bottom flashing to cover the full footprint of unit and extend up 2" on 3 sides. **All openings around the top, sides and bottom must be caulked and sealed. Care must be taken not to plug the openings in the front of the base pan of the unit. If the optional wall sleeve is used, caulk the spaces between the sleeve and the wall. Completely fill the clearance between the unit and the wall sleeve with a polyurethane foam sealant.**

4. During periods of rain and wind the primary drainage path may not be adequate to handle the load. Secondary precautions may also be required but not limited to the following:

- a. Seal flashing to unit
- b. Floor drain
- c. Additional field sealing of sheet metal joints
- d. Sealing of unused access opening

5. Clearances to air inlets and outlets must be adequate to ensure no air flow obstructions or recirculation of condenser air flow. Care must be taken to locate the coil side of the unit away from loose debris that may clog airflow inlet or outlet.

6. Some architectural designs of buildings will require the unit to be mounted behind a decorative grille. The performance (capacity and efficiency) of the unit may be reduced with the use of these decorative grilles. The less resistive these grilles are to air flow, the better the units performance will be. Outdoor louvers provided by others **must be** approved by NCP to maintain unit performance and warranty.

7. If the unit is mounted behind a decorative grille, one or both of the following items **must be** done to eliminate recirculation of air to the unit:

- a. The front of the unit must be mounted tight to the inside of the architectural grille
- b. A barrier must be provided to prevent recirculation of air to the unit (mixing of inlet and outlet air) when the front of the unit is mounted back from the inside of the architectural grille

8. The unit must not be mounted in dead-end hallways or areas where there is no fresh outside air circulation. Cool fresh outside air **must be** provided for best unit operation. Thru-the-wall units may not be located where hot exhausts from clothes dryer vents, kitchen vents, steam vents or corrosive fumes could come in contact with coil side of unit.

9. 30" clearance is required for service accessibility on the inside service panel.

10. A minimum 48" of vertical clearance and 12" of horizontal clearance between units is required to minimize recirculation of condenser exhaust air. For horizontal clearances less than 12", please consult National Comfort Products.

11. Care must be taken when locating the unit. Locate away from bedrooms as operational sounds may be objectionable. (See sound cover on page 12)

Refrigerant Piping

1. The maximum length of refrigerant lines from the through the wall unit to indoor unit should NOT exceed **fifty (50) feet** without contacting National Comfort Products.

2. The maximum vertical change should not exceed twenty (20) feet without contacting National Comfort Products.

**Maximum Allowable Liquid Line Pressure Drop = 50 PSI
Subtract .43 PSI for each foot of Liquid Lift (if any)
Do Not Exceed this value when selecting Liquid Line**

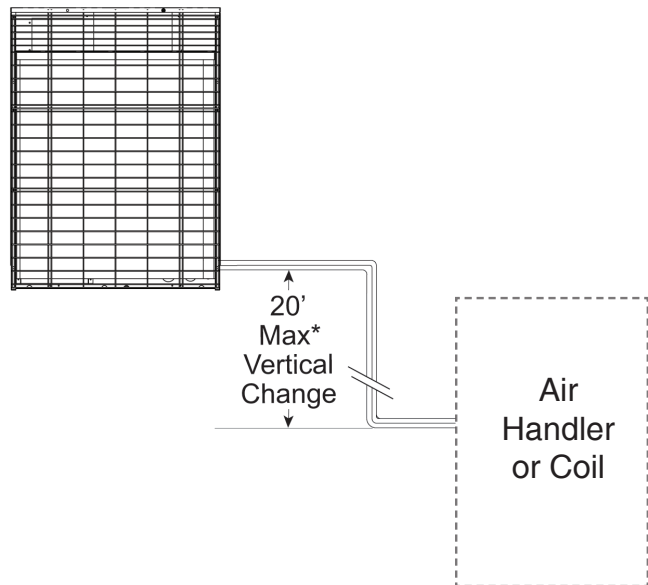
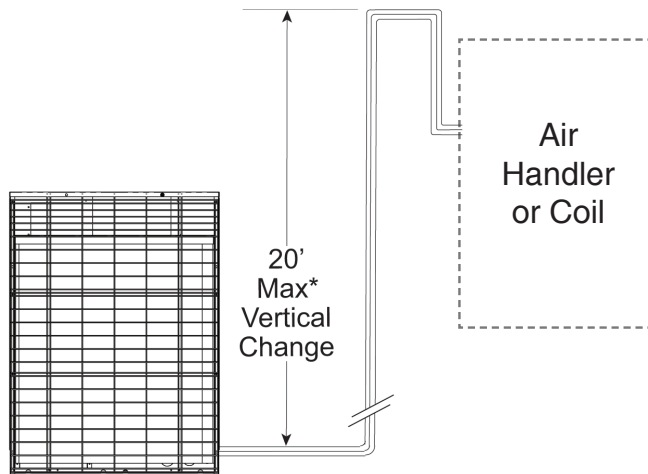
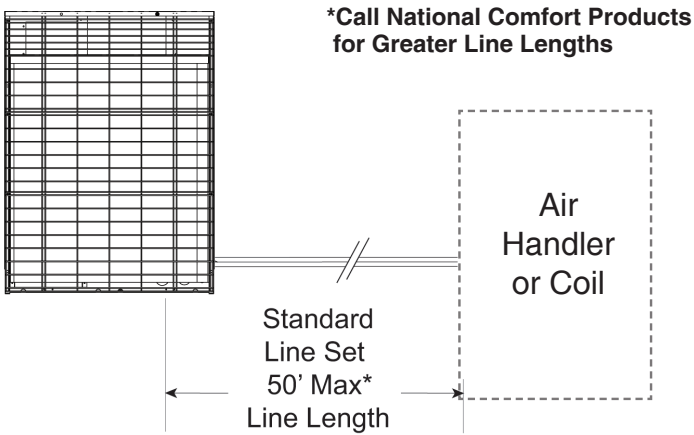

3. The unit has internally mounted service valves. Field tubing may be routed through the locations provided in either the top or rear panels. Care should be taken not to block access to internal components. Seal unused knockouts with high grade sealant. Gaskets are provided for liquid and suction lines.

Note: Always use refrigeration grade copper tubing that is internally clean and dry for refrigerant lines. Use clean hard drawn copper tubing if no appreciable amount of bending is necessary. If soft copper is used, avoid sharp bends which may cause a restriction. Always use heat sink materials during brazing to prevent damage to service valves (See page 6).

4. Run refrigerant lines as directly as possible. Field piping inside the condensing unit should not block access to major components. Refrigerant lines should not be in direct contact with the floor or ceiling joists. Use insulated or suspension type hangers. When refrigerant lines run through a wall, seal openings around the lines with a flexible material to avoid vibration to the structure.

Note: Take precautions to prevent noise within the building structure due to vibration transmission from the refrigerant lines. For example:

When the refrigerant lines have to be fastened to floor joists or other framing in a structure, use isolation type hangers.

Isolation hangers should also be used when refrigerant lines are run in stud spaces or enclosed ceilings.

Where the refrigerant lines run through a wall or sill, they should be insulated and isolated.

Isolate lines from all ductwork.

Minimize the number of 90° turns.

5. Standard refrigeration piping practices must be employed when installing traps. When installing the condenser below the evaporator, the suction line must be trapped with an inverted trap the height of the evaporator coil. Consult the factory when total equivalent length of refrigerant lines exceeds 50 ft.

6. Insulate the vapor line with a minimum 1/2" foam rubber or other type insulation having an adequate vapor barrier. For indoor units with a TXV, a liquid line filter drier must be installed (SPORLAN #C-083-S or similar).

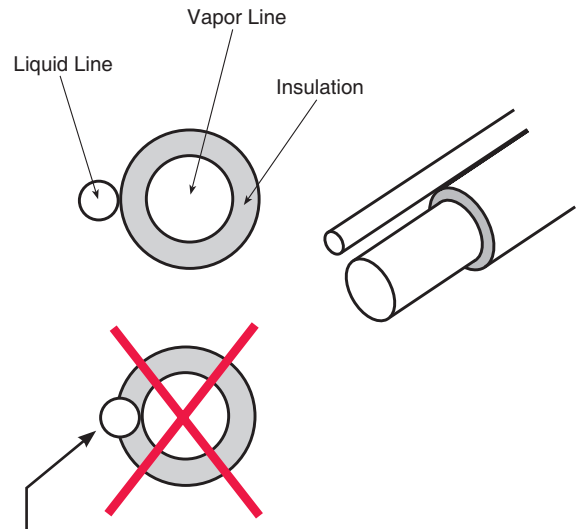

IMPORTANT: The Vapor Line must always be insulated. **DO NOT** allow the liquid line and vapor line to come in direct (metal to metal) contact.

7. Install the refrigerant lines using the following procedure (See Steps 1 thru 4.)

- a. Remove the service port caps and Schrader Cores of the liquid line service valve and the vapor line service valve of the condensing unit. Connect low pressure dry nitrogen to the liquid line valve service port.

CAUTION: Dry nitrogen should always be supplied through the tubing while it is being brazed, as the high temperature required for brazing will cause oxidation of the copper unless an inert atmosphere is provided. The flow of dry nitrogen should continue until the joints have cooled. Always use a pressure regulator and safety valve to ensure that only low pressure nitrogen is introduced into the tubing. Only a small flow is necessary to displace air and prevent oxidation.

- b. Provide a heat sink at the service valve such as wrapping a wet rag around it, to prevent damage during the brazing operation
- c. Braze the liquid line to the service valve. Allow the nitrogen to keep flowing when brazing the refrigerant line until all brazed joints are completed.
- d. Provide a heat sink to the vapor line service valve of the condensing unit
- e. Braze the vapor line to the service valve
- f. When tubing installation is complete, seal openings around tubing where tubing enters the unit cabinet.

Step 1:

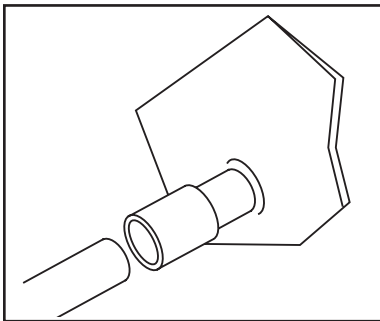

The tubing should be cut square. Make sure it is round and free of burrs at the connecting ends. Clean the tubing to prevent contaminants from entering the system.

Step 2:

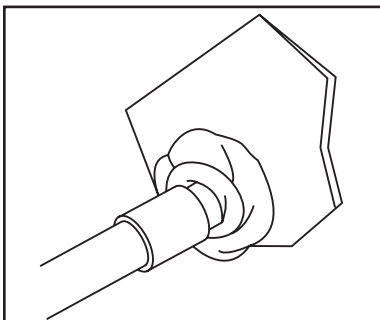

Wrap a wet rag around the copper stub of the service valve before brazing.

Step 3:

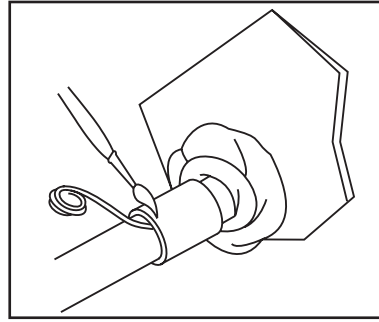

Flux the copper tube and insert into the stub. Braze the joint. No flux is necessary if a low to zero-silver braze alloy is used.

Step 4:

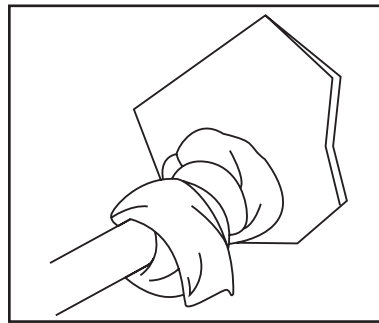

After brazing, quench with a wet rag to cool the joint and remove any flux residue.

Leak Checking

Leak checking of refrigerant line braze joints and evaporator unit using dry nitrogen. (See Step 5a)

1. Replace service port cap of the vapor line service valve (cap was removed for brazing operations).
2. Connect dry nitrogen source to the service port of the liquid line service valve. Pressurize refrigerant lines and indoor coil to approximately 100 psig.
3. Check for leaks using a liquid soap solution. If any leaks are detected, purge the nitrogen, repair the leak(s) and repeat the leak check procedure.

Leak checking of refrigerant line braze joints and evaporator unit using R410a refrigerant. (See Step 5b)

1. Connect R410a source to the service port of the liquid line service valve. Use of a manifold gauge set will facilitate connecting and disconnecting of the refrigerant source for leak checking. Pressurize refrigerant lines and indoor coil with refrigerant gas.
2. Leak check with an electronic leak detector or liquid soap solution. If any leaks are detected, use a refrigerant recovery system to remove the refrigerant. Repair the leak(s) and repeat the leak check procedure.

Step 5a:

Using a liquid soap solution

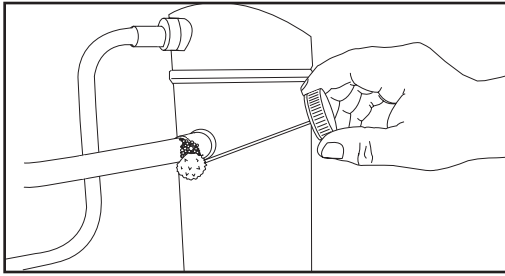

Apply liquid soap solution to check for leaks

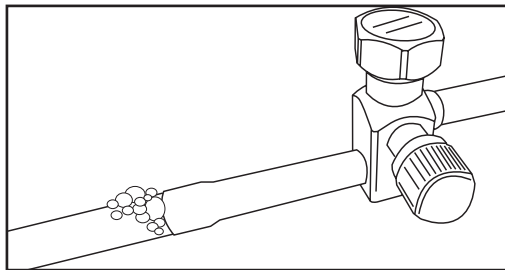

Bubbles forming in the liquid soap solution indicates a leak

Step 5b:

Using an electronic leak detector

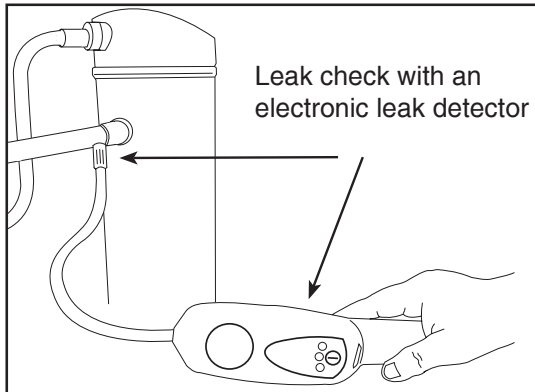

Leak check with an electronic leak detector

Evacuation

1. Connect the vacuum pump to the service ports of the liquid line and vapor line service valves. If the vacuum pump lines do not contain shut-off valves, hook up the vacuum pump through a manifold gauge set, as the vacuum pump lines must be closed for step 4 below.

- a. If the evacuation is being performed on a new system installation, the condensing unit service valves should be kept in the closed position. The vacuum pump will then be able to evacuate the refrigerant lines and evaporator coil.

- b. If the evacuation is being performed on an installation where the condensing unit factory charge has been lost, the service valves should be opened.

2. Following the vacuum pump manufacturer's instructions, allow the pump to operate until the system has been evacuated down to 300 microns.

Note: Check for leaks if unable to get to 300 microns.

3. Allow the pump to continue running an additional 15 minutes. Turn off the pump and leave connections secured. After 10 minutes if system fails to hold 500 microns or less, check all connections for tight fit and repeat evacuation procedure.

4. Isolate the vacuum pump by closing the shut-off valves on vacuum pump lines or test gauge manifold.

5. Open the service valves. Opening the service valves will allow the refrigerant in the condensing unit to enter the refrigerant lines and evaporator coil. The vacuum pump can now be disconnected. (See Step 6 and 7)

Step 6:

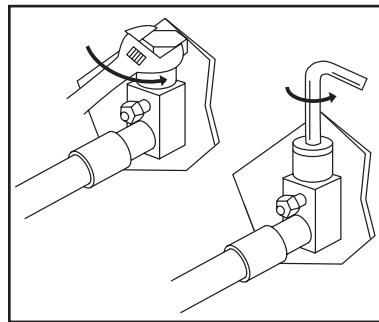

This is not a back seating valve. To open the valve remove the valve cap with an adjustable wrench. Insert a 3/16" or 5/16" hex wrench into the stem. Back out counter-clockwise until the valve stem just touches the retaining ring. **CAUTION** (Certain combination hex wrenches designed for service valves may not properly seat into the valve stem and may lead to stripping. Make sure the hex wrench is seated completely in the valve when first opening)

Step 7:

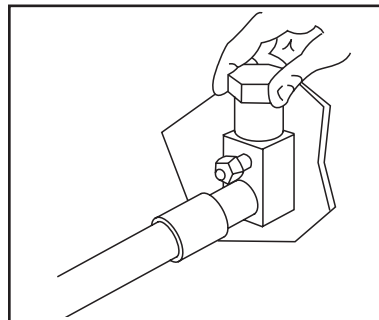

Replace the valve cap finger tight then tighten an additional 1/12 turn or 1/2 hex flat. A metal-to-metal seal is now complete. Complete normal factory recommended procedures.

Electrical Connections

Note: Make certain that the volts, hertz, and phase correspond to that specified on the unit rating plate, and that the service provided by the utility is sufficient to handle the additional load imposed by this equipment.

Make all electrical connections in accordance with the National Electrical Code and any pertinent local codes or ordinances. Use a separate branch electrical circuit for this unit. Locate a disconnecting means within sight of and readily accessible to the unit.

- a. Line Voltage Connections
- b. Connect the single phase power supply to unit contactor terminal L1 and L2
- c. Connect ground wire to lug
- d. Low Voltage Connections

Consult the indoor unit installation instructions for thermostat connections. **Use a 2-wire thermostat cable between the units.**

When locating the room thermostat, it should be in the natural circulating path of room air. Avoid locations where the thermostat would be exposed to cold air infiltration; drafts from windows, doors or other openings leading to the outside; exposure to air currents from warm-or-cold air registers or to exposure where the natural circulation of the air is cut off, such as behind doors, above or below mantels, shelves, etc.

Electrical - Low Voltage

Low Voltage Maximum Wire Length:

Table defines the maximum total length of low voltage wiring from the condensing unit to the indoor unit and to the thermostat.

24 VOLTS	
WIRE SIZE	MAX. WIRE LENGTH
18 AWG	150 ft.
16 AWG	225 ft.
14 AWG	300 ft.

Low Voltage Hook-up Diagram

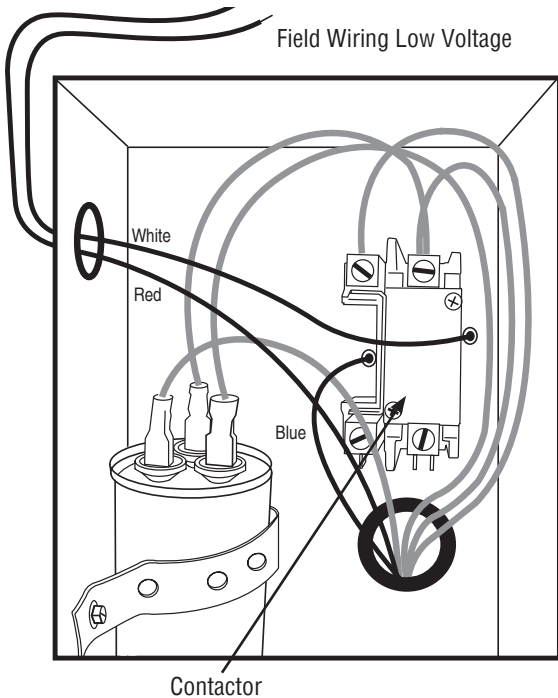

Electrical - High Voltage

NOMINAL VOLTAGE	MINIMUM VOLTAGE	MAXIMUM VOLTAGE
208-230	197	253

Please refer to pages 14-17 for proper capacitor sizing.

High Voltage Power Supply

⚠ WARNING

LIVE ELECTRICAL COMPONENTS!

During installation, testing, servicing and troubleshooting of this product, it may be necessary to work with live electrical components. Failure to follow all electrical safety precautions when exposed to live electrical components could result in death or serious injury.

The high voltage power supply must agree with the equipment nameplate.

OR

Make certain that the volts, hertz, and phase correspond to that specified on the unit rating plate, and that the service provided by the utility is sufficient to handle the additional load imposed by this equipment.

Power wiring must comply with national, state, and local codes.

Follow instructions on unit wiring diagram located on the inside of the access door, or cabinet and in the wiring diagrams included with the unit.

Install a separate disconnect switch at the location of the through the wall unit.

Disconnect Switch

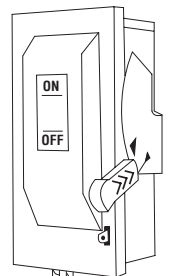

Ground the unit per national, state, and local code requirements.

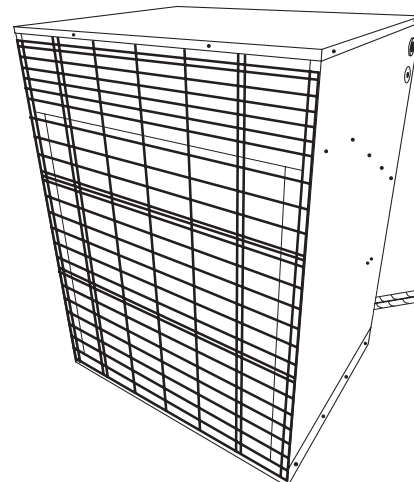

Thru-the-Wall Condensing Unit

Start Up

1. Ensure that directions on Page 4 through 8 have been completed. Check numbers once done.
2. Turn on disconnect(s) to apply power to all equipment.
3. Wait one (1) hour before starting the unit if compressor crankcase heater accessory is used and the Outdoor Ambient is below 70°
4. Set system thermostat to ON.

Sequence of Operations

On a “call for cooling”, the thermostat completes circuits R-Y and R-G. Circuit R-Y energizes the contactor starting the condenser fan motor and compressor circuit. R-G energizes the indoor unit blower relay starting the indoor blower motor.

When the thermostat is satisfied, its contacts open, de-energizing the contactor and blower relay. Compressor and motors should stop.

NATIONAL COMFORT PRODUCTS R-410A CHARGING CHART

LIQUID PRESSURE AT SERVICE VALVE (psig)	°F	°F	°F	°F	°F	°F	°F	°F	°F	°F	°F
	12	13	14	15	16	17	18	19	20	21	22
	R-410A REQUIRED LIQUID LINE TEMPERATURE (°F)										
251	72	71	70	69	68	67	66	65	64	63	62
259	74	73	72	71	70	69	68	67	66	65	64
266	76	75	74	73	72	71	70	69	68	67	66
274	78	77	76	75	74	73	72	71	70	69	68
283	80	79	78	77	76	75	74	73	72	71	70
291	82	81	80	79	78	77	76	75	74	73	72
299	84	83	82	81	80	79	78	77	76	75	74
308	86	85	84	83	82	81	80	79	78	77	76
317	88	87	86	85	84	83	82	81	80	79	78
326	90	89	88	87	86	85	84	83	82	81	80
335	92	91	90	89	88	87	86	85	84	83	82
345	94	93	92	91	90	89	88	87	86	85	84
364	98	97	96	95	94	93	92	91	90	89	88
374	100	99	98	97	96	95	94	93	92	91	90
384	102	101	100	99	98	97	96	95	94	93	92
395	104	103	102	101	100	99	98	97	96	95	94
406	106	105	104	103	102	101	100	99	98	97	96
416	108	107	106	105	104	103	102	101	100	99	98
427	110	109	108	107	106	105	104	103	102	101	100
439	112	111	110	109	108	107	106	105	104	103	102
450	114	113	112	111	110	109	108	107	106	105	104
462	116	115	114	113	112	111	110	109	108	107	106
474	118	117	116	115	114	113	112	111	110	109	108

Note: It is important to return in the spring or summer to accurately charge the system in the cooling mode when outdoor ambient temperature is above 55° F.

Stabilize the system by operating for a minimum of 20 minutes. At startup, or whenever charge is removed or added, the system must be operated for a minimum of 20 minutes to stabilize before accurate measurements can be made.

System Charge Adjustment

Temperature Measurements

Check that the outdoor temperature is 65°F or higher before adjusting charge based on subcooling. Subcooling (in cooling mode) is the only

recommended method of charging the system. For reference, use the charge chart above and refer to page 17 for your systems proper subcooling value. For best results the indoor temperature should be kept between 70° F to 80° F.

Installers Notes:

- Condenser door must be in place while adjusting subcooling
- Ambient temperature must be between 65°F-95°F
- Indoor return air temperature must be above 70°F
- Allow 20 minutes of run time at premium conditions before adjusting charge
- Driving rain against the condenser coil can affect setting proper subcooling
- Add charge to increase subcooling
- Remove charge to decrease subcooling
- Indoor units must be equipped with a thermal expansion valve (TXV)

Refrigerant Charging

The condensing units are tested in factory based on 10 ft of refrigerant lines. If the actual line length is greater or less than 10ft, add or remove refrigerant at the rate of 0.6 ounces per foot.

If the condensing unit charge was lost for any reason, add factory refrigerant charge listed on condensing unit data plate plus adjustments describe above to meet the required subcool as instructed on page #17. If the unit is operating during charge adjustment, the access panel must be in place to prevent high head pressure which would shut down the unit.

Note: For longer linesets, the charge **MUST** be adjusted to meet the required subcool and superheat values as instructed on page #17 for cooling operation. Use actual linear length with the table below.

When replacing an R-22 system, it is recommended that new line sets be used. If the old line sets are to be used, they **MUST** be flushed with a commercial flushing agent. R410A refrigerant oil is not compatible with mineral oil.

IMPORTANT: The outdoor unit comes with refrigerant, which may not be enough for your system. When installing a condensing unit with a matched Indoor coil or air-handler, system charge and TXV setting **MUST** be adjusted to meet the required subcool and superheat values as instructed on page #17. All other indoor units will require factory testing and certification with DOE. Be sure both service valves are closed during tubing installation and leak checked to avoid loss of charge. A liquid line filter drier must be installed (SPORLAN #083-S or similar).

Ounces & Pounds of R410A Required for Line Sets

Weight	Tubing Size	10'	15'	20'	25'	30'	35'	40'	45'	50'
Ounces	3/8" - 3/4"	0	3	6	9	12	15	18	21	24
Pounds	3/8" - 3/4"	0	0.1875	0.375	0.5625	0.75	0.9375	1.125	1.3125	1.5

CAUTION

Low Suction Pressure Operation! Compressor Damage!

Do not operate with a restricted suction. Do not operate with the lowpressure cut-out bridged. Do not operate compressor without enough system charge to maintain at least 0.5 bar (7.25 psi) suction pressure. **Allowing pressure to drop below 0.5 bar (7.25 psi) for more than a few seconds may overheat scrolls and cause early drive bearing damage.**

The system should be liquid-charged through the liquid-receiver shut-off valve or through a valve in the liquid line. The use of a filter drier in the charging line is highly recommended. Because R410A and R407C are blends and scrolls have discharge check valves, systems should be liquid-charged on both high and low sides simultaneously to ensure a positive refrigerant pressure is present in the compressor before it runs. The majority of the charge should be placed in the high side of the system to prevent bearing washout during first-time start on the assembly line.

1. Connect the charging cylinder to the manifold gauge set. Open the charging cylinder valve and bleed air out of the charging hose at the manifold gauge set connection.
2. Tighten the manifold gauge set charging connection. Open the main manifold gauge set valve and introduce refrigerant into the liquid side of the system.

3. When the correct refrigerant charge level is obtained, remove the manifold gauge set.

4. Replace the gauge port caps.

Permanently stamp the unit data plate with the total amount of refrigerant in the system.

Note: All information based on the following Air Flow Chart. Required superheat varies for each system. Refer to page 17 for recommended superheat. Superheat temperature measurements should be taken within 3 feet of the compressor suction line connection.

Air Flow Chart for Coil Only Matches

Outdoor Model	Indoor Model	Airflow (SCFM) ¹
NCP4181000A-**	NCC418AA-*	620
NCP4241000A-**	NCC424AA-*	620
NCP4301000A-**	NCC430AA-*	890
NCP4183000A-**	NCC418AA-*	620
NCP4243000A-**	NCC424AA-*	620
NCP4303000A-**	NCC430AA-*	890
NCP4184000A-**	NCC418AA-*	820
NCP4244000A-**	NCC424AA-*	820
NCP4185000A-**	NCC418AA-*	820
NCP4245000A-**	NCC424AA-*	820
NCP4305000A-**	NCC430AA-*	920

1. The airflow is conducted at wet coil conditions. The airflow in the table above is recommended to get best performance out of your system

Note: Oil charge is polyester 32bce.

CAUTION: It is very important that when charging a system to charge liquid refrigerant into the high side only. It is not good practice to flood liquid refrigerant from a refrigerant cylinder into the crankcase of the a stationary compressor through the suction line. If additional charge is required carefully charge liquid incrementally into the low side of the system with the compressor operating. Excessive liquid introduced into the suction line will damage the compressor.

Air Flow Chart for Air Handler Matches

Outdoor Model	Indoor Model	Motor Speed Color (Tap)	Static (in. wc.)	Airflow (SCFM) ¹
NCP4181000A-**-**	NAH424MF*-**-**	Black (2)	0.3	600
NCP4241000A-**-**	NAH430MF*-**-**	Blue (3)	0.3	790
NCP4301000A-**-**	NAH430MF*-**-**	Red (5)	0.3	950
NCP4183000A-**-**	NAH424MF*-**-**	Black (2)	0.3	600
NCP4243000A-**-**	NAH430MF*-**-**	Blue (3)	0.3	790
NCP4303000A-**-**	NAH430MF*-**-**	Red (5)	0.3	950
NCP4184000A-**-**	NAH424MF*-**-**	Black (2)	0.3	600
NCP4244000A-**-**	NAH430MF*-**-**	Blue (3)	0.3	790
NCP4185000A-**-**	NAH424MF*-**-**	Black (2)	0.3	600
NCP4245000A-**-**	NAH430MF*-**-**	Blue (3)	0.3	790
NCP4305000A-**-**	NAH430MF*-**-**	Red (5)	0.3	950

1. The airflow is conducted with a filter at wet coil conditions. The airflow in the table above is recommended to get best performance out of your system

Maintenance

1. Annually clean the inside of the unit to keep the weep holes in the base pan open to assure proper drainage of water from the unit.
2. Keep the condenser coil clean and free of anything that restricts free air flow. For sea coast applications the condenser coil should be washed periodically to remove salt accumulation.
3. Reduced indoor air flow through a duct system will cause the indoor coil to ice up in cooling. If this condition is not corrected, premature system failure will result. Indoor air filters should be cleaned and changed regularly.
4. Annually check units mounting to structure to ensure integrity. Seal between cabinet and/or sleeve for air or water leakage. Check exposed surfaces for corrosion. Replace or paint parts as required. This maintenance is critical to prevent stains and damage to exterior surface of building.
5. Inspect refrigerant piping for leaks and suction line insulation for deterioration and damage. Improper insulation can cause condensate water damage.
6. Pressure and temperature readings of the high and low sides of the system should be checked for proper superheat and/or subcooling. Correct if required. See System Charge Adjustment on Page 9.
7. Check motor amperage to nameplate value, inspect the motor mounting and prop fan hub for tightness and rust or corrosion. Observe the prop fan blade for balance.
8. Inspect the wire connections and contactor dry contacts for evidence of arcing, over heating, or deterioration.

Checkout Procedures and Troubleshooting

Checkout Procedures

After installation has been completed, it is recommended that the system be checked against the following list:

- | | |
|---|--------------------------|
| 1. Leak check refrigerant lines. | <input type="checkbox"/> |
| 2. Properly insulate suction lines and fittings. | <input type="checkbox"/> |
| 3. Properly secure and isolate all refrigerant lines. | <input type="checkbox"/> |
| 4. Seal passages through masonry. If mortar is used, prevent mortar from coming into direct contact with copper tubing. | <input type="checkbox"/> |
| 5. Verify that all electrical connections are tight. | <input type="checkbox"/> |
| 6. Observe outdoor fan during on cycle for clearance and smooth operation. | <input type="checkbox"/> |
| 7. Be sure the indoor condensate line drains freely. Pour water into drain pan. | <input type="checkbox"/> |
| 8. Be sure that supply registers and return grilles are open and unobstructed. | <input type="checkbox"/> |
| 9. Be sure that a return air filter is installed. | <input type="checkbox"/> |
| 10. Be sure that the correct indoor airflow setting is used. | <input type="checkbox"/> |

Service Access

Note: 30" of clearance is required for service accessibility on the inside. All units are serviceable from the inside.

Noise

We design our unit as quiet as possible; please keep in mind when locating the unit that it does make noise. Use common precautions as you would for other mechanical appliances pertaining to noise.

Outdoor Sound: 79.8 dBA (AHRI Standard 270-2008)

Sound Cover

As an option, we offer an **Insulated Sound Cover** for installation over the inside cover of the unit.

Indoor Sound

Without Insulated Sound Cover: 70.4 dBA

With Insulated Sound Cover: 68.3 dBA

(AHRI Standard 350-2008)

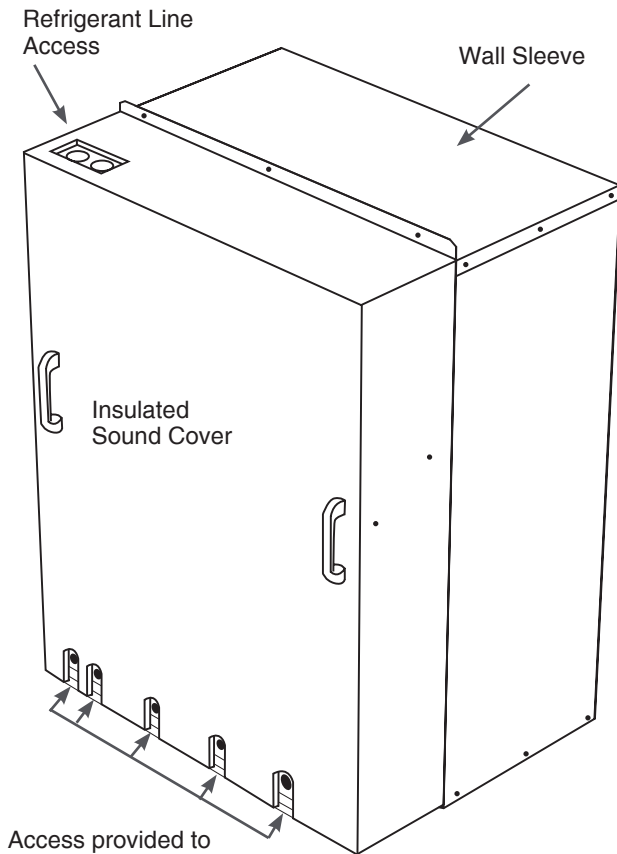

Access provided to
Line Set Connections,
Line Voltage, Low Voltage
and Refrigerant Line
Access

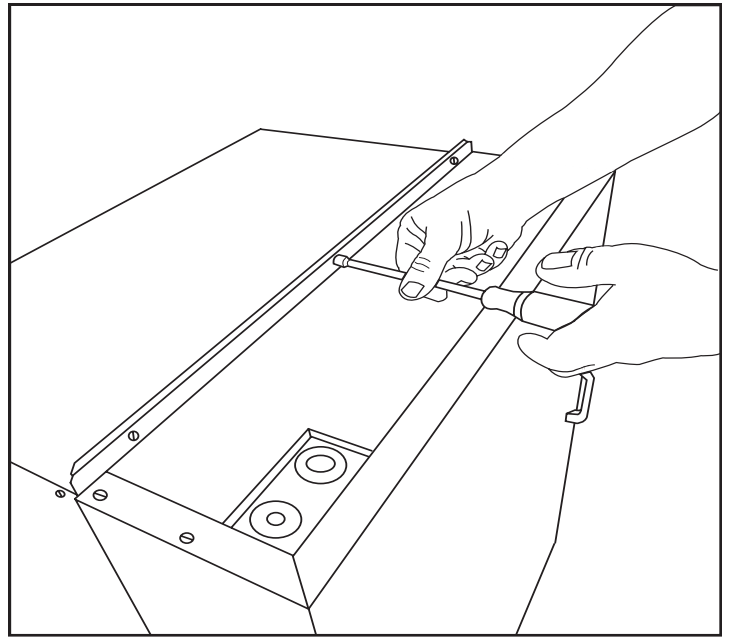

The Insulated Sound Cover will be supplied with insulated handles installed and assembled.

To install onto the unit, either the top or bottom will need to be removed depending on the exit point of the tubing. (3 screws)

Sound Covers Available

- 1000 I.D. Cover
- 3000 I.D. Cover
- 4000 I.D. Cover
- 5000 I.D. Cover



IMPORTANT!!!

BEFORE REMOVING A WARRANTY COMPRESSOR,
PLEASE FILL OUT THE FOLLOWING
AND CALL (800) 523-7138.

**REMOVAL OF COMPRESSOR WITHOUT FACTORY VERIFICATION
 CAN LEAD TO WARRANTY CREDIT BEING DENIED**

1. Incoming Voltage to Compressor at Contactor is: _____ Volts \sim AC
2. Compressor Starting AMP Draw: _____ A
3. Compressor Winding OHM Reading between Terminals C & S: _____ Ω
4. Compressor Winding OHM Reading between Terminals C & R: _____ Ω
5. Compressor Winding OHM Reading between Terminals R & S: _____ Ω
6. Compressor Winding OHM Reading between Terminals C & Ground: _____ Ω
7. Compressor Winding OHM Reading between Terminals R & Ground: _____ Ω
8. Compressor Winding OHM Reading between Terminals S & Ground: _____ Ω

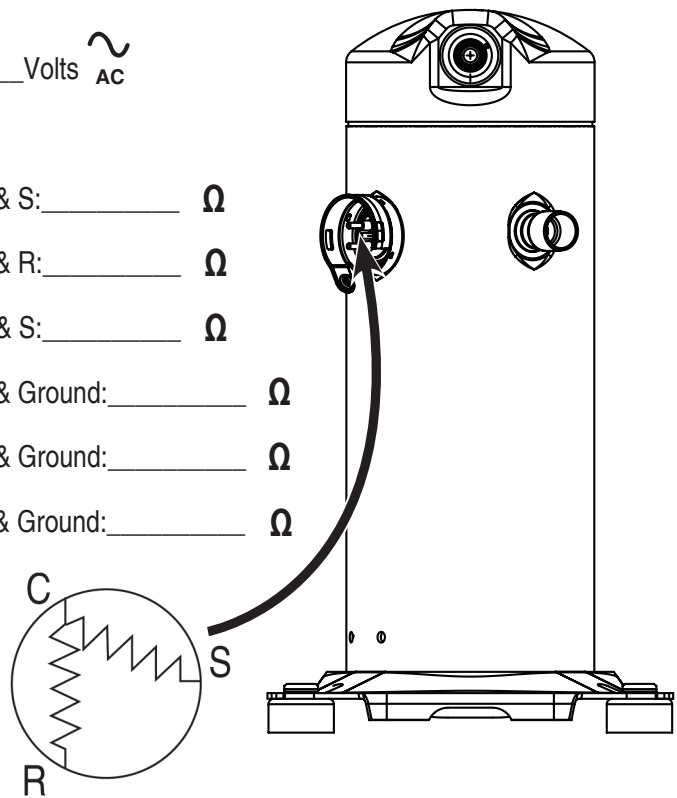

9. Run Capacitor Reading from HERM to COM: _____ μ F
10. Start Capacitor Reading if Used: _____ μ F

TOP VIEW OF CAPACITOR

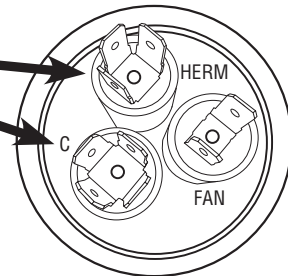

11. If the Compressor is Operating Please Indicate the Following:

Suction Pressure: _____ psig Discharge Pressure _____ psig

Super Heat: _____ F Subcooling: _____ F

208-230 VAC NOMINAL VOLTAGE
 197 VAC MINIMUM VOLTAGE
 253 VAC MAXIMUM VOLTAGE

CAPACITOR CHART	
NCP418(1000,3000,4000)	= 30+5/440VAC
NCP418(5000)	= 30/440VAC
NCP424(1000,3000,4000)	= 35+5/440VAC
NCP424(5000)	= 35/440VAC
NCP430(1000,3000,4000,5000)	= 35/440VAC

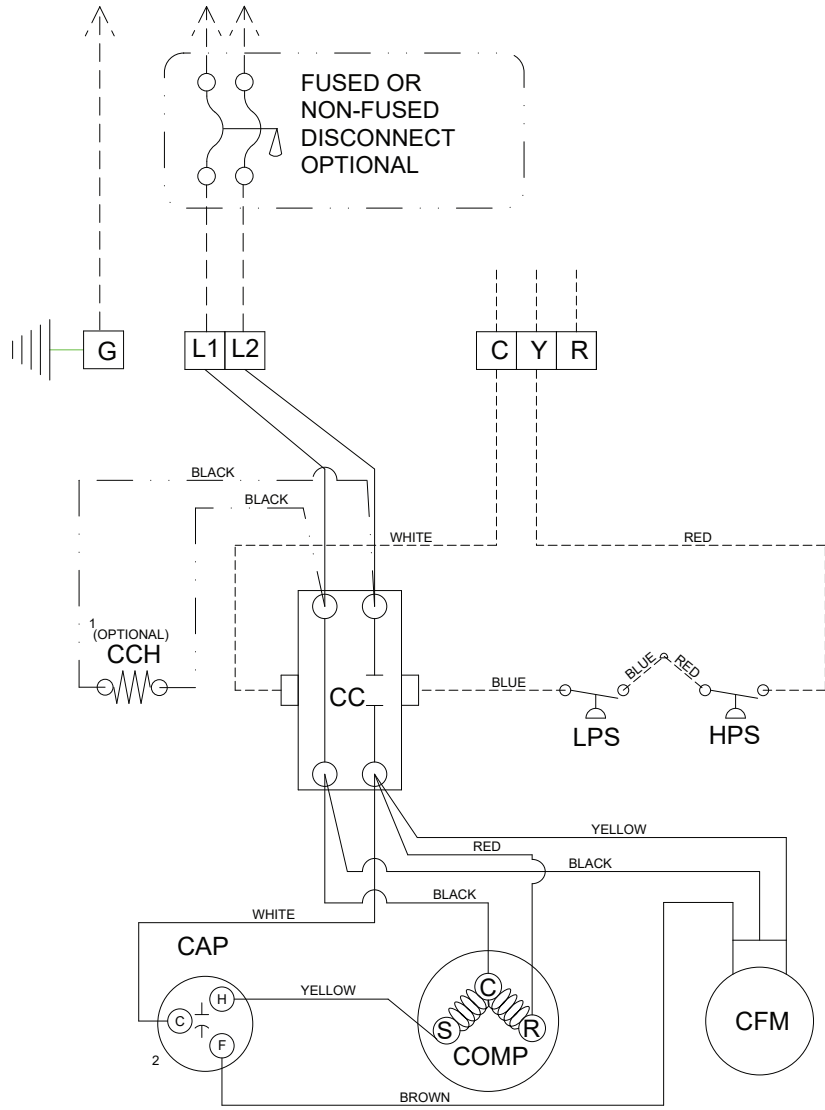

NOTE:
 1. Crankcase heater is available as a factory installed option.
 2. Certain units utilize CFM's that do not require a capacitor. This BROWN wire will not be included and a single capacitor will be used for the COMP. See Capacitor Chart above.



539 DUNKSFERRY RD.
 Bensalem, Pa. 19020
 Phone: 800-523-7138
 FAX: 215-639-1674

WIRING DIAGRAM
NCP SERIES
1000, 3000, 4000 & 5000

DRAWN BY	DATE	JOB NUMBER
BS	12/1/2022	14299226

LEGEND
 CAP - DUAL CAPACITOR
 CC - COMPRESSOR CONTACTOR
 CCH - CRANKCASE HEATER (OPTIONAL)
 COMP - COMPRESSOR
 CFM - CONDENSER FAN MOTOR
 HPS - HIGH PRESSURE SWITCH
 LPS - LOW PRESSURE SWITCH

1000 Series w/ matches up to 12.5 SEER2*					
All Units 208/230-1~60Hz					
Model	Shipping weight (lbs)	Compressor		MCA	MOP
		RLA	LRA		
NCP4181000A-**	160	10.3	45.7	14.20	20
NCP4241000A-**	165	11.7	59.5	15.90	25
NCP4301000A-**	170	12.8	65	17.80	30
Cond. Fan Motor Specs		418/424		1/4 HP, 1600 RPM, 1.3 FLA	
		430		1/5 HP, 1650 RPM, 1.8 FLA	
Condenser Coil Specs		3.61 ft ² Face Area, 16 FPI			
Dimensions		26 1/4" W x 28 5/8" H x 18 1/2" D			
Liquid Valve		3/8"	Suction Valve		3/4"

*When matched with NAH4**MF Air Handler

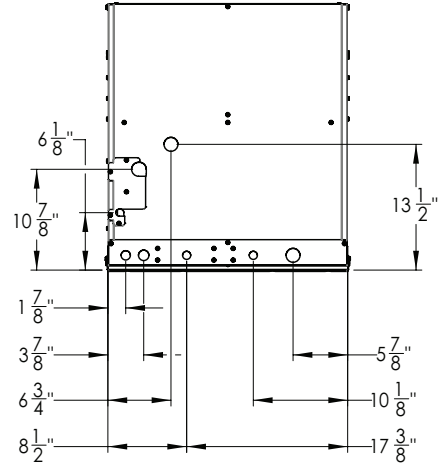
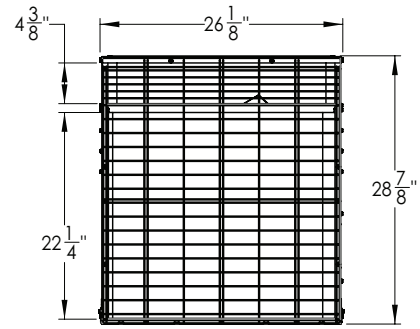
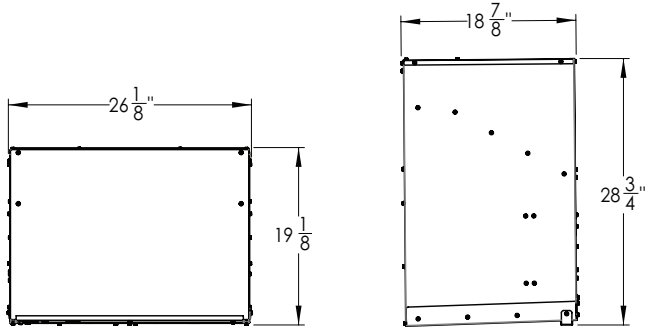

3000 Series w/ matches up to 12.5 SEER2*					
All Units 208/230-1~60Hz					
Model	Shipping weight (lbs)	Compressor		MCA	MOP
		RLA	LRA		
NCP4183000A-**	160	10.3	45.7	14.20	20
NCP4243000A-**	165	11.7	59.5	15.90	25
NCP4303000A-**	170	12.8	65	17.80	30
Cond. Fan Motor Specs		418/424		1/4 HP, 1600 RPM, 1.3 FLA	
		430		1/5 HP, 1650 RPM, 1.8 FLA	
Condenser Coil Specs		3.77 ft ² Face Area, 16 FPI			
Dimensions		24 1/8" W x 32" H x 18 1/2" D			
Liquid Valve		3/8"	Suction Valve		3/4"

* When matched with NAH4**MF Air Handler

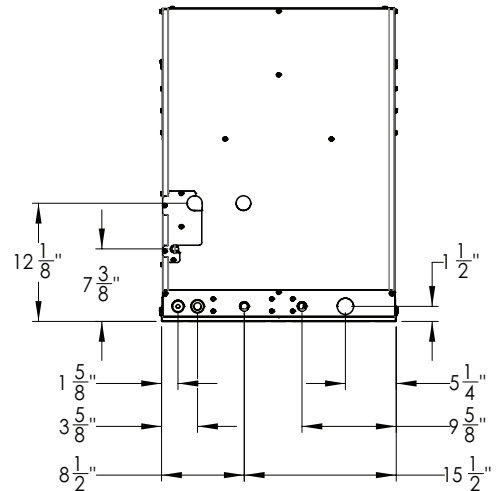
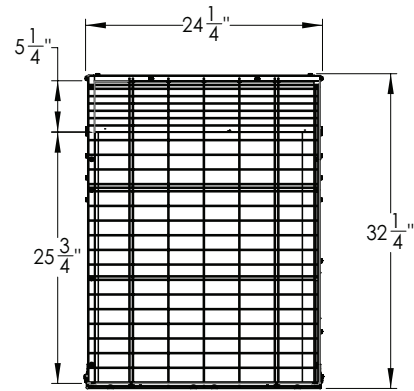
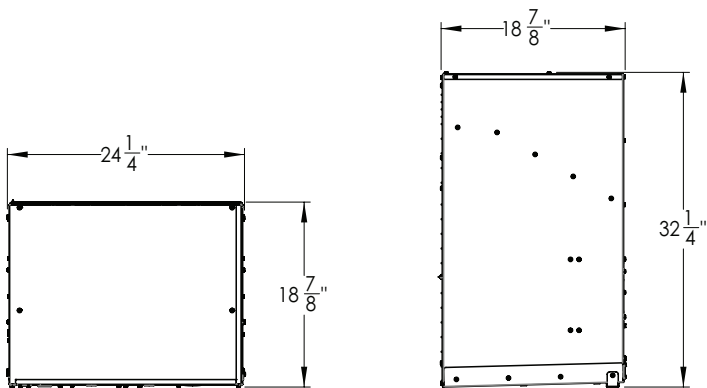

4000 Series w/ matches up to 12.5 SEER2*					
All Units 208/230-1~60Hz					
Model	Shipping weight (lbs)	Compressor		MCA	MOP
		RLA	LRA		
NCP4184000A-**	160	10.3	45.7	14.70	20
NCP4244000A-**	170	11.7	59.5	16.40	25
Cond. Fan Motor Specs		1/5 HP, 1650 RPM, 1.8 FLA			
Condenser Coil Specs		3.14 ft² Face Area, 16 FPI			
Dimensions		30" W x 23" H x 22 1/2" D			
Liquid Valve		3/8"	Suction Valve	3/4"	

* When matched with NAH4**MF Air Handler

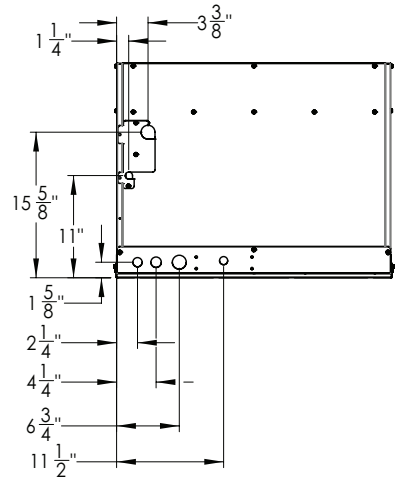
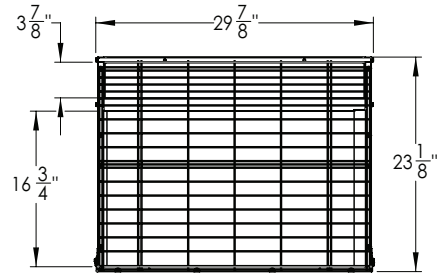
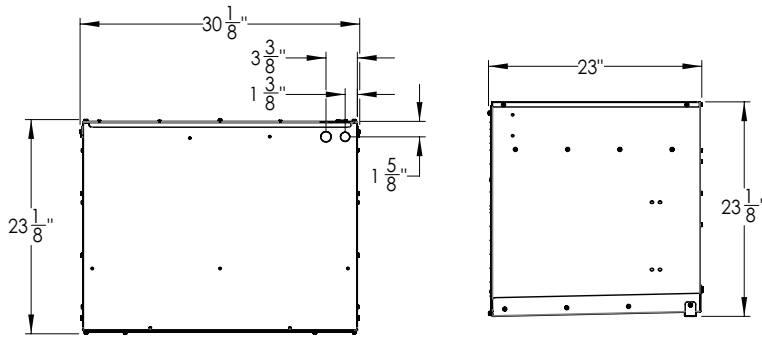

5000 Series w/ matches up to 14 SEER2*					
All Units 208/230-1~60Hz					
Model	Shipping weight (lbs)	Compressor		MCA	MOP
		RLA	LRA		
NCP4185000A-**	170	10.3	45.7	14.68	20
NCP4245000A-**	185	11.5	59.5	16.18	25
NCP4305000A-**	190	14.1	67.9	19.43	30
Cond. Fan Motor Specs		1/5 HP, 1650 RPM, 1.8 FLA			
Condenser Coil Specs		418		4.59 ft² Face Area 16 FPI	
		424/430		4.59 ft² Face Area 14 FPI	
Dimensions		26 7/8 W" x 38 7/8" H x 18 1/2" D			
Liquid Valve		3/8"	Suction Valve	3/4"	

* When matched with NAH4**MF Air Handler

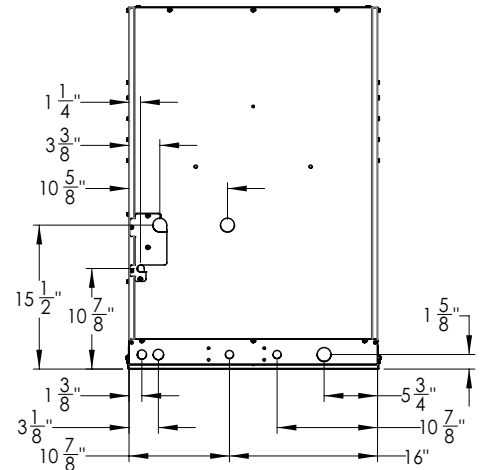
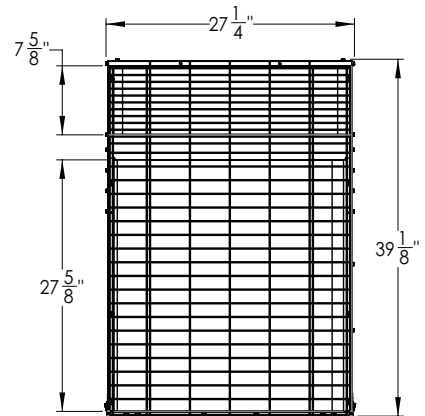
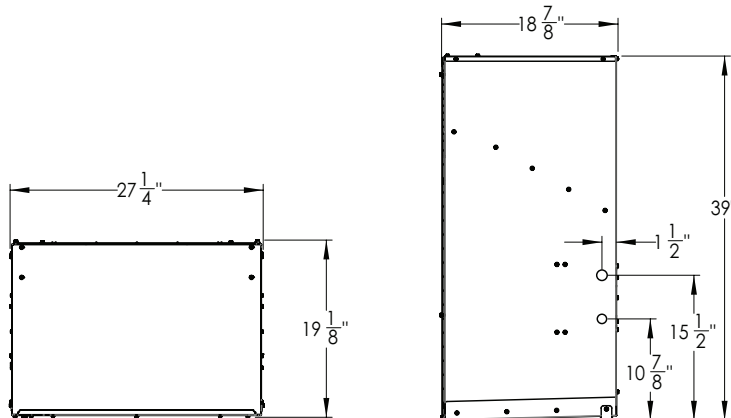

NCP Condensers with Cased Coil

Outdoor Model	Indoor Model	Rated Capacity (Btu/h)	Rated EER2 ¹	Nominal Airflow ² (SCFM)	SEER2 ³	Liquid Subcool ⁴ (°F)	Suction Superheat ⁵ (°F)
NCP4181000A-**	NCC418AA-*	18000	10.2	620	11.7	15-19	9-13
NCP4241000A-**	NCC424AA-*	22600	10.5	820	11.7	12-16	13-17
NCP4301000A-**	NCC430AA-*	26400	10.2	890	11.7	15-19	12-16
NCP4183000A-**	NCC418AA-*	18000	10.2	620	11.7	15-19	12-16
NCP4243000A-**	NCC424AA-*	22600	10.5	820	11.7	12-16	12-16
NCP4303000A-**	NCC430AA-*	26800	10.2	890	11.7	14-18	11-15
NCP4184000A-**	NCC418AA-*	18000	10.5	620	11.7	16-20	12-16
NCP4244000A-**	NCC424AA-*	22600	10.5	820	11.7	14-18	13-17
NCP4185000A-**	NCC418AA-*	18500	11	620	12	12-16	12-16
NCP4245000A-**	NCC424AA-*	24000	11	820	12	12-16	13-17
NCP4305000A-**	NCC430AA-*	28000	10.5	920	12	13-17	12-16

1. EER2 is determined based on the Evaporator match listed in this table
2. Airflow values are determined at wet coil conditions
3. SEER2 is determined base on the Evaporator match listed in this table
4. Subcooling must be measured at condenser liquid valve
5. Superheat must be measured at evaporator outlet at suction line

NCP Condensers with Air Handler

Outdoor Model	Indoor Model	Indoor Motor Speed	Rated Capacity (Btu/h)	Rated EER2 ¹	Nominal Airflow ² (SCFM)	SEER2 ³	Liquid Subcool ⁴ (°F)	Suction Superheat ⁵ (°F)
NCP4181000A-**	NAH424MF*-**	Black (2)	18000	11	600	12.5	15-19	7-11
NCP4241000A-**	NAH424MF*-**	Blue (3)	22600	11	790	12.5	13-17	11-15
NCP4301000A-**	NAH430MF*-**	Red (5)						
NCP4183000A-**	NAH424MF*-**	Black (2)	18000	11	600	13	14-18	7-11
NCP4243000A-**	NAH430MF*-**	Blue (3)	23000	11	790	13	14-18	12-16
NCP4303000A-**	NAH430MF*-**	Red (5)						
NCP4184000A-**	NAH430MF*-**	Black (2)	18000	11	600	12.5	16-20	8-12
NCP4244000A-**	NAH430MF*-**	Blue (3)	23000	11	790	12.5	14-18	12-16
NCP4185000A-**	NAH424MF*-**	Black (2)	18000	12	600	14	11-15	14-18
NCP4245000A-**	NAH430MF*-**	Blue (3)	24000	12	790	14	12-16	12-16
NCP4305000A-**	NAH430MF*-**	Red (5)	28400	11.5	950	13.5	15-19	12-16

1. EER2 is determined based on the Evaporator match listed in this table
2. Airflow values are determined at wet coil conditions
3. SEER2 is determined base on the Evaporator match listed in this table
4. Subcooling must be measured at condenser liquid valve
5. Superheat must be measured at evaporator outlet at suction line

1000 Series Replacement Parts Guide

Item	Description	NCP4181000A-**	NCP4241000A-**	NCP4301000A-**
1	Contactor	142-62-082	142-62-082	142-62-082
2	Start/Run Capacitor	142-25-376	142-25-375	142-25-395
3	Low Pressure Switch	142-65-026	142-65-026	142-65-026
4	High Pressure Switch	142-65-029	142-65-029	142-65-029
5	Compressor	142-10-264	142-10-265	142-10-267
6	Liquid Service Valve	142-58-614	142-58-614	142-58-614
7	Vapor Service Valve	142-58-616	142-58-616	142-58-616
8	Condenser Coil	142-08-361	142-08-360	142-08-360
9	Motor	142-70-049	142-70-049	142-70-056
10	Fan Blade	142-14-040	142-14-040	142-14-040
11	Motor Mount	142-70-103	142-70-103	142-70-103
12	Base Pan	143-56-042	143-56-042	143-56-042
13	Unit Leveler	143-56-047	143-56-047	143-56-047
14	Access Panel	143-56-041	143-56-041	143-56-041
15	Top Panel	143-56-046	143-56-046	143-56-046
16	Right Side Panel	143-56-045	143-56-045	143-56-045
17	Left Side Panel	143-56-043	143-56-043	143-56-043
18	Wire Grill	142-69-001A	142-69-001A	142-69-001A
19	Radial Fan Mount	143-56-044	143-56-044	143-56-044
20	Touch Up Paint	142-99-630	142-99-630	142-99-630
21	Air Diffuser	143-56-039	143-56-039	143-56-039
22	Air Diffuser Rear	143-56-040	143-56-040	143-56-040

3000 Series Replacement Parts Guide

Item	Description	NCP4183000A-**	NCP4243000A-**	NCP4303000A-**
1	Contactor	142-62-082	142-62-082	142-62-082
2	Start/Run Capacitor	142-25-376	142-25-375	142-25-395
3	Low Pressure Switch	142-65-026	142-65-026	142-65-026
4	High Pressure Switch	142-65-029	142-65-029	142-65-029
5	Compressor	142-10-264	142-10-265	142-10-267
6	Liquid Service Valve	142-58-614	142-58-614	142-58-614
7	Vapor Service Valve	142-58-616	142-58-616	142-58-616
8	Condenser Coil	142-08-356	142-08-357	142-08-357
9	Motor	142-70-049	142-70-049	142-70-056
10	Fan Blade	142-14-040	142-14-040	142-14-040
11	Motor Mount	142-70-103	142-70-103	142-70-103
12	Base Pan	143-56-024	143-56-024	143-56-024
13	Unit Leveler	143-56-026	143-56-026	143-56-026
14	Access Panel	143-56-021	143-56-021	143-56-021
15	Top Panel	143-56-029	143-56-029	143-56-029
16	Right Side Panel	143-56-025	143-56-025	143-56-025
17	Left Side Panel	143-56-022	143-56-022	143-56-022
18	Wire Grill	142-69-003A	142-69-003A	142-69-003A
19	Radial Fan Mount	143-56-023	143-56-023	143-56-023
20	Touch Up Paint	142-99-630	142-99-630	142-99-630
21	Air Diffuser	143-56-019	143-56-019	143-56-019
22	Air Diffuser Rear	143-56-018	143-56-018	143-56-018

4000 Series Replacement Parts Guide

Item	Description	NCP4184000A-**	NCP4244000A-**
1	Contactor	142-62-082	142-62-082
2	Run Capacitor	142-25-387	142-25-395
3	Low Pressure Switch	142-65-026	142-65-026
4	High Pressure Switch	142-65-029	142-65-029
5	Compressor	142-10-264	142-10-265
6	Liquid Service Valve	142-58-614	142-58-614
7	Vapor Service Valve	142-58-616	142-58-616
8	Condenser Coil	142-08-359	142-08-358
9	Motor	142-70-056	142-70-056
10	Fan Blade	142-14-047	142-14-047
11	Motor Mount	142-70-110	142-70-110
12	Base Pan	143-56-051	143-56-051
13	Unit Leveler	143-56-056	143-56-056
14	Access Panel	143-56-050	143-56-050
15	Top Panel	143-56-055	143-56-055
16	Right Side Panel	143-56-054	143-56-054
17	Left Side Panel	143-56-052	143-56-052
18	Wire Grill	142-69-004A	142-69-004A
19	Radial Fan Mount	143-56-053	143-56-053
20	Touch Up Paint	142-99-630	142-99-630
21	Air Diffuser	143-56-048	143-56-048
22	Air Diffuser Rear	143-56-049	143-56-049

5000 Series Replacement Parts Guide

Item	Description	NCP4185000A-**-**	NCP4245000A-**-**	NCP4305000A-**-**
1	Contactactor	142-62-082	142-62-082	142-62-082
2	Run Capacitor	142-25-387	142-25-395	142-25-395
3	Low Pressure Switch	142-65-026	142-65-026	142-65-026
4	High Pressure Switch	142-65-029	142-65-029	142-65-029
5	Compressor	142-10-264	142-10-266	142-10-268
6	Liquid Service Valve	142-58-614	142-58-614	142-58-614
7	Vapor Service Valve	142-58-616	142-58-616	142-58-616
8	Condenser Coil	142-08-372	142-08-371	142-08-371
9	Motor	142-70-056	142-70-056	142-70-056
10	Fan Blade	142-14-040	142-14-040	142-14-040
11	Motor Mount	142-70-103	142-70-103	142-70-103
12	Base Pan	143-56-020	143-56-020	143-56-020
13	Unit Leveler	143-56-005	143-56-005	143-56-005
14	Access Panel	143-56-017	143-56-017	143-56-017
15	Top Panel	143-56-003	143-56-003	143-56-003
16	Right Side Panel	143-56-036	143-56-036	143-56-036
17	Left Side Panel	143-56-035	143-56-035	143-56-035
18	Wire Grill	142-69-005	142-69-005	142-69-005
19	Radial Fan Mount	143-56-037	143-56-037	143-56-037
20	Touch Up Paint	142-99-630	142-99-630	142-99-630
21	Air Diffuser	143-56-011	143-56-011	143-56-011
22	Air Diffuser Rear	143-56-012	143-56-012	143-56-012



539 Dunksferry Road | Bensalem, PA 19020 | 215-244-1400 | 1-800-523-7138 | Fax: 215-639-1674

THRU-THE-WALL CONDENSING UNIT & HEAT PUMP LIMITED WARRANTY

1. National Comfort Products warrants to its customers that its product shall be free from defects in material and workmanship under normal use and regular service and maintenance as follows:

COMPRESSORS: For five years from the date of original installation.

ALL OTHER PARTS: For all other parts except the Compressor, for two years from the date of original installation.

Customer must register the product within 60 days of purchase. If Customer cannot adequately document date of installation, then, for purposes of determining the warranty period, the date of installation shall be 60 days from the date of purchase. The 2 year parts warranty is effective for units purchased after January 1, 2016.

2. This warranty does not extend to any damages or losses due to misuse, accident, abuse, neglect, normal wear and tear, negligence (other than National Comfort's), unauthorized modification or alteration; use beyond rated capacity; unsuitable power sources or environmental conditions; improper installation, repair, handling, maintenance or application; damage as a result of fire, wind, floods, lightning, or corrosive conditions; or any other cause not the fault of National Comfort. By way of example and without limitation, the following do not constitute a defect in workmanship and materials and are not covered by this warranty: slugging of liquid refrigerant or oil, unstable line voltage, lightning, operating without proper lubrication, and operating without factory provided safeties. Any installation that impairs or impedes air flow negatively impacts performance and causes premature equipment failure that voids this warranty. For example, installation behind a brick facade or the addition of a brick pattern facade, i.e. pigeon holes impedes air flow and shall void this warranty.

3. SOLE WARRANTY

The warranties identified herein constitute National Comfort's sole and exclusive warranties with respect to the goods and are in lieu of and exclude all other warranties, express or implied, arising by operation of law or otherwise, including without limitation, merchantability and fitness for a particular purpose whether or not the purpose or use has been disclosed to National Comfort in specifications, drawings or otherwise, and whether or not National Comfort's goods are specifically designed and/or manufactured by National Comfort for Customer's use or purpose.

4. LIMITATION OF REMEDY

The sole and exclusive remedy for breach of any warranty hereunder (other than the warranty provided herein) shall be limited to repair, replacement, credit or refund of the purchase price to distribution as set forth herein.

National Comfort is not responsible for any other item including but not limited to local transportation, freight, removal of any compressor or part, any labor associated therewith, service or diagnosis calls, refrigerant, or costs for returning any defective compressor or part.

5. LIMITATION OF WARRANTY

NATIONAL COMFORT MAKES NO OTHER WARRANTIES, EXPRESS OR IMPLIED, ORAL OR WRITTEN, RELATED TO THE GOODS, INCLUDING ANY WARRANTY OF MERCHANTABILITY OF FITNESS FOR A PARTICULAR PURPOSE, WHICH ARE EXPRESSLY DISCLAIMED. NATIONAL COMFORT SHALL NOT BE LIABLE FOR SPECIAL, INCIDENTAL, OR CONSEQUENTIAL DAMAGES OR LOSSES FROM ANY CAUSE WHATSOEVER, INCLUDING, WITHOUT LIMITATION, LOSS OF USE, COMMERCIAL PROFITS, OR CUSTOMER GOODWILL, AND ANY OTHER CLAIMS BASED ON CONTRACT OR TORT, WHETHER OR NOT ARISING FROM NATIONAL COMFORT'S NEGLIGENCE.

National Comfort shall not be liable for damages caused by delay in performance and the remedies of Customer set forth in this agreement are exclusive. In no event, regardless of the form of the claim or cause of action (whether based in contract, infringement, negligence, strict liability, other tort or otherwise) shall National Comfort's liability to Customer and/or its customers exceed the price paid by Customer for the specific goods or portion of the goods provided by National Comfort giving rise to the claim or cause of action, and Customer shall indemnify and hold harmless National Comfort for any damages incurred by National Comfort in excess thereof. Customer agrees that in no event shall National Comfort's liability to Customer and/or its customers extend to include incidental, consequential, or punitive damages.

The term "consequential damages" shall include, but not be limited to, loss of anticipated profits, business interruption, loss of use, revenue, reputation and data, costs incurred, including without limitation, for capital, fuel, power and loss or damage to capital or equipment. Customer agrees that all instructions and warnings supplied by National Comfort will be passed on to those persons

Continued on next page

who use the Goods. National Comfort's Goods are to be used in their recommended applications and all warning labels adhered to the Goods by National Comfort are to be left intact.

It is expressly understood that any technical advice furnished by National Comfort before or after delivery in regard to the use or application of the Goods is furnished without charge, and National Comfort assumes no obligation or liability for the advice given or results obtained, all advice being given and accepted at Customer's sole risk.

6. WARRANTY PROCEDURE

For All Warranty Claims. Customer must register the product with National Comfort within 60 days from purchase. Failure to timely register the product may void the warranty. Any claim for warranty shall be made within thirty days of discovery and in any event, within thirty days from removal of the compressor or part from the unit. Failure to make a timely claim shall void the warranty. Prior authorization from National Comfort is required for all warranty claims. Any claim for warranty must be first reported to National Comfort in writing specifying the unit, serial number, date of purchase and date of original installation. Customer shall also request a Return Material Authorization ("RMA") from National Comfort to initiate the warranty claim process. Issuance of an RMA by National Comfort is not an acknowledgment that the defect is covered by this Warranty. Any replacement compressor or part is warranted for the original product warranty, or for one year from the date of shipment of the replacement compressor/part, whichever is later.

A. Compressors. In addition to the above-referenced requirements, Customer is also required to purchase a replacement compressor and return the original compressor to National Comfort at National's discretion. If the defect is reported to National Comfort within one year from the date of original installation or within 20 months from the date of manufacture of the compressor (as determined by the compressor serial number), whichever occurs first, then Customer may take the compressor to any Authorized Copeland Distributor for replacement of said compressor. If the defect is reported to National Comfort after one year from the date of installation or after 20 months from the date of manufacture of the compressor (as determined by the compressor serial number), whichever occurs first, but before the expiration of five years from the date of installation, then the compressor should be returned to National Comfort at National's discretion and Customer shall purchase a new compressor. If National Comfort determines that there is a defect in material or workmanship that is covered by this Warranty, then National shall credit Customer for the cost of the new replacement compressor. If National Comfort determines that the defect in material or workmanship is not covered by this Warranty, then no credit shall be issued. A copy of the invoice of the replacement compressor and completed RMA must accompany the compressor. National Comfort, at its sole discretion, may also require Customer to supply the compressor tag. The failure to follow this procedure shall render the warranty void.

B. Other Parts. In addition to the above-referenced requirements, Customer is required to purchase a replacement part for the original part for which Customer is making a warranty claim. The original part for which warranty is claimed is to be returned to National Comfort at National's discretion, freight prepaid. If National Comfort determines that there is a defect in material or workmanship in the part that is covered by this Warranty, then National Comfort shall credit Customer for the cost of the new replacement part. If National Comfort determines that the defect in material or workmanship is not covered by this Warranty, then no credit shall be issued. A copy of the invoice of the replacement part and completed RMA must accompany the original part for which warranty is claimed. National Comfort reserves the right to request additional documentation. The failure to follow this procedure shall render the warranty void.

7. SHIPPING INSTRUCTIONS

A. Compressors. Returned compressors must be totally secured by use of shipping lugs taken from the replacements compressors and clearly marked with the RMA number. Do not use tape, rags or putty to seal the compressor. Line connections should be sealed with rubber plugs. All scroll compressors must be securely bolted, banded, and stretch wrapped to a skid in the upright position.

B. Parts. All other returned parts must be securely packaged and clearly marked with its corresponding RMA number provided from NCP.



**NATIONAL[®]
COMFORT
PRODUCTS**

HEATING & A/C EQUIPMENT

National Comfort Products
539 Dunksferry Road | Bensalem, PA 19020-5908
(800) 523-7138
Fax (215) 639-1674

